

CARTRIDGE PILOT VALVES

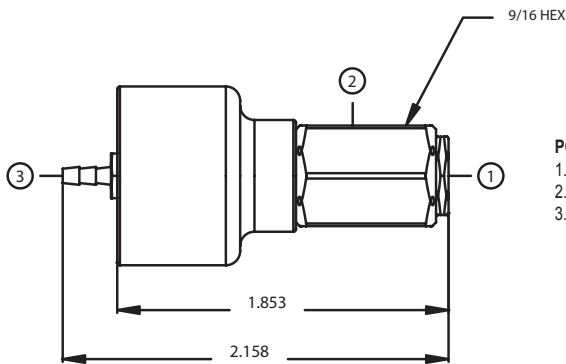

PORT DEFINITIONS
 1. 10-32 Female Input
 2. 10-32 Female Output
 3. 1/16 Barb Pilot

Design Considerations

The Cartridge Pilot Valve Series promotes a compact Normally Open design with multiple 2-Way (Non-Exhausting) or 3-Way (Exhausting) 10-32 Female porting configurations to fit the exact end use application. The Pilot Valves require approximately 35 psi to actuate and have a 1/6B Pilot Port Standard. The Dual Exhausting Pilot Valve relieves air through a .063 side orifice and through the bottom .063 exhaust orifice. The Cartridge Pilot Valve may be ordered with any size barb for the pilot.

Specifications

Body: Electroless Nickel Plated Brass
 Stem: Electroless Nickel Plated Brass

Maximum Operating Pressure – 0 - 125 psi
 Maximum Operating Temperature – -25°F to 180°F
 Flow Rate – 3 SCFM @ 50 psi

Example of How to Order

CPB 2 NC-B, 1/16B W/LPA

