

PILOT ACTUATED NEEDLE VALVE

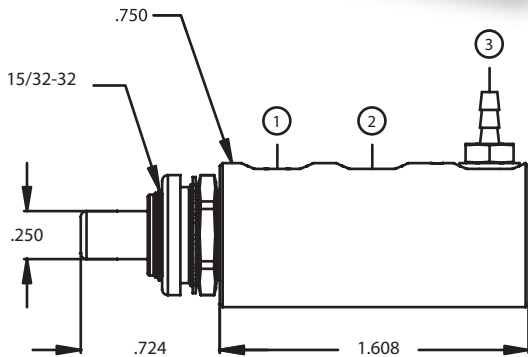

PORT DEFINITIONS
 1. 10-32 Female Input
 2. 10-32 Female Output
 3. 1/16 Barb Pilot

Design Considerations

The Pilot Actuated Needle Valve promotes a compact design with multiple configurations to fit the exact end use application. A 6.5 Turn Needle Adjustment is standard. The Panel Mount Needle Valves require a .500 hole and are supplied with two Electroless Nickel Plated Panel Nuts and lock washer.

Specifications

Body & Panel Nuts: Electroless Nickel Plated Brass
 Stem: Brass
 Panel Mounting: 1/2" Panel Hole, 1/4" Max. Thickness

Maximum Operating Pressure – 0 - 125 psi
 Maximum Operating Temperature – -25°F to 180°F
 Flow Rate – 2.1 SCFM @ 50 psi

Example of How to Order

PA NV NC-B, 10/32F, *

